

ACCUMULATOR FAILURE

ADVANTAGES

USE OF AN ACCUMULATOR eliminates the need to “oversize” the actuator as with a spring fail unit. The accumulator puts no load on the power module during normal operation so actuator size is reduced. REXA’s unique accumulator technology uses the power module to recharge the accumulator, thus eliminating the need for a separate re-charge pump and associated plumbing. This feature allows all components of the accumulator system to be located on the actuator. A failure may be initiated by loss of electrical power or an independent trip signal. After a failure the accumulator is re-charged by the actuator’s power module prior to resuming normal operation.

SYSTEM OPERATION

System operation is based on a piston type accumulator with high-pressure nitrogen gas on one side of the piston and oil on the other. The accumulator is sized to provide a minimum of 2000 PSI oil pressure to the actuator during failure, thus insuring that the actuator will always produce its rated output.

Upon receipt of a failure or trip signal, two solenoid valves open simultaneously, one allowing oil under pressure from the accumulator to enter the appropriate side of the hydraulic cylinder, and the other allowing the oil displaced from the opposite side of the cylinder into a holding reservoir (see Fig. 1)*. When the trip signal ends or power is restored, the PCP senses the low pressure in the accumulator. This signal tells the PCP to open both solenoids and run the power module in the direction required to drive the actuator in the fail direction. As the actuator is already at its failure position, oil will be drawn from the reservoir and pumped into the accumulator (see Fig. 2). When the proper recharge pressure is reached, the PCP stops the power module and closes the solenoid valves. Normal operation is now resumed.

The PCP continuously monitors the pressure in the accumulator during normal operation and sets off an alarm if low pressure is detected.

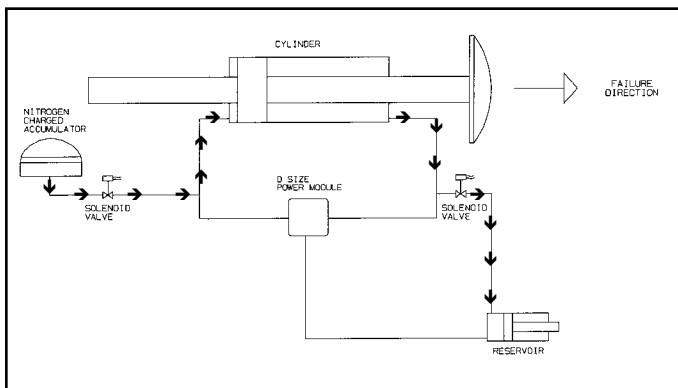

Figure 1

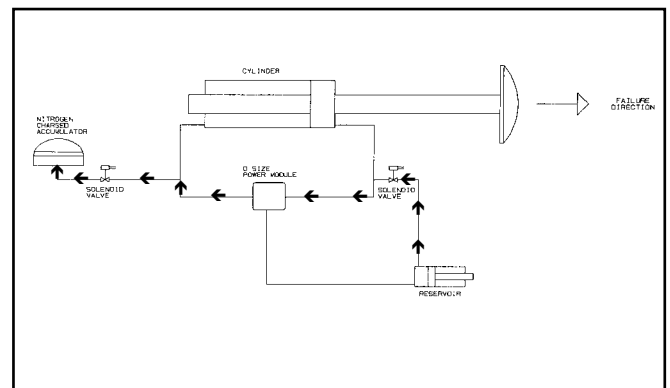

Figure 2

* Standard accumulator units are not equipped with an adjustable fail stop. Applications that do not have a built-in stop at the fail position may require an adjustable fail stop in the actuator. Consult factory for details.

ACCUMULATOR SELECTION GUIDE

R Series	Estimated Fail Time*(seconds)
600	.25
1200	.25
2500	.30
5000	.40
10000	.50
20000	.75
50000	1.5
100000	3.0
200000	6.0
400000	12.0

**Fail time will vary with ambient temperature. An adjustable fail speed limiter is available. Consult factory for details*

L Series	Estimated Fail Time*(seconds)
2000-2	.25
2000-8	.50
2000-11	.60
4000-2	.40
4000-4	.5
5000-11	1.25
5000-16	1.5
5000-22	2.0
10000-2	.6
10000-6	1.25
10000-11	2
10000-16	3
10000-22	3.75
20000-2	1
20000-4	1.5
20000-6	1.5
20000-8	3
20000-11	3.75
20000-16	6
20000-22	8
40000-2	1.5
40000-4	3
40000-6	4
40000-8	6
40000-11	8
40000-16	11
40000-22	15
80000-2	3
80000-4	6
80000-6	8
80000-8	11
80000-11	15
120000-2	4
120000-4	9
120000-6	12